

Fluorine in Nitrogen

The mixture contains 10% or 20% fluorine in nitrogen. This mixture of two permanent gases will not separate or stratify during shipment, storage or use. Packaged in high-pressure cylinders at a nominal pressure of 150 barg (2175 psig) at 15°C (59°F), the mixture is a toxic, corrosive, oxidizer, compressed gas. Fluorine has a sharp, pungent odor that can be detected by most people at very low levels. The 10% to 20% range concentration was selected as the level allowing storage of the maximum amount of fluorine at a concentration that minimizes the reactivity of the fluorine. Table 1 lists the physical and chemical properties of the components of this mix.

Table 1: Physical and Chemical Properties

	Fluorine	Nitrogen	Mix
Appearance	pale yellow gas	colorless gas	
Odor	sharp, pungent, irritating	odorless, nonirritating	
Molecular Formula	F ₂	N ₂	
Molecular Weight	38.0	28.01	
Melting Point	-219.67°C (-363.41°F)	-209.95°C (-345.91°F)	
Boiling Point	-188.2°C (-306.8°F)	-195.83°C (-320.5°F)	
Gas Density @ 21.1°C (calculated for the the 10% F ₂ in N ₂ mixture)			1.21 kg/m ³ (0.076 lb/ft ³)
Specific Volume @ 21.1°C (calculated for the the 10% F ₂ in N ₂ mixture)			0.826 m ³ /kg (13.16 ft ³ /lb)
Specific Gravity @ 21.1°C (calculated for the mixture) (air=1)			0.97

Warning

Improper storage, handling, or use of fluorine mixtures can result in serious injury and/or property damage. Use this product in accordance with the Air Products and Chemicals, Inc. Safety Data Sheet (SDS) for 20% fluorine, balance nitrogen.

Safety considerations

Health effects

Fluorine is the toxic component in this mixture. It is very irritating and corrosive to all living tissue. Pure fluorine has an LC₅₀ of 185 ppm (1 hr. rat). Nitrogen is a simple asphyxiant and considered nontoxic. This mixture is less toxic than pure fluorine.

Chronic fluorine exposure may cause abnormal calcium accumulation in bone structure (fluorosis) due to low-level systemic absorption. The potential for the formation of hydrogen fluoride exists with every exposure; therefore, its toxicity must also be considered. Depending on conditions, hydrogen fluoride may convert to hydrofluoric acid (aqueous) at varying concentrations. When aqueous hydrofluoric acid concentration is below 50%, it has delayed (up to six hours) symptoms of exposure. In addition, when fluorine mixtures are involved in a fire, the products of combustion can also be toxic.

Note: In systems the fluorine/nitrogen mixtures are blended with additional nitrogen to lower the concentration to approximately 1%. The toxicity and reactivity of 1% fluorine/nitrogen is considerably less than pure fluorine. The LC50 for a mixture with this concentration would be 18,500 ppm (1.85%).

Acute exposure guideline levels (AEGs) are for use by emergency response personnel facing chemical disasters. The AEGs themselves are not regulatory levels, but are expected to be used by regulatory officials, industry officials, and emergency responders in a variety of ways and situations. The three proposed AEGs for fluorine reflect the scarcity of human data and the short exposure durations employed in the human and animal studies. The AEG-1 value was based on

Table 2: Exposure Levels

Exposure Limit	Fluorine	Nitrogen
OSHA: PEL-TWA	0.1 ppm	none
ACGIH: TLV-TWA	0.1 ppm	simple asphyxiant
NIOSH: IDLH	25 ppm	none

Table 3: Proposed AEG Values for Fluorine

Classification	30 min	1 hour	4 hours	8 hours
AEG-1	1.7 ppm	1.7 ppm	1.7 ppm	1.7 ppm
AEG-2	11 ppm	5.0 ppm	2.3 ppm	1.5 ppm
AEG-3	19 ppm	13 ppm	5.7 ppm	3.9 ppm

AEG-1 level at or above which notable discomfort/irritation could occur.
AEG-2 level at or above which irreversible or disabling effects could occur.
AEG-3 level at or above which life-threatening effects or death could occur.

a study with human volunteers. The AEG-2 and -3 values are based on animal studies where exposures for less than lethal effects did not exceed one hour. Therefore the confidence in the 30- and 60-minute AEGs is moderate, while the confidence in the extrapolation to longer exposure times (4- and 8-hour) is less strong.

Reactivity

Fluorine is the most powerful oxidizing element. It reacts with almost everything, including some of the rare gases like xenon. Therefore special steps, such as special cleaning and passivation procedures, must be taken to protect systems. Fluorine reacts with moisture to form hydrofluoric acid. Hydrofluoric acid is not as aggressive to metal as some of the other inorganic acids like hydrochloric or sulfuric, but it is many times more aggressive to human tissue. Because fluorine reacts with everything, corrosion of materials in contact with fluorine is dependent upon the fluoride formed with the material. If the fluoride is volatile or in the form of loose flakes, new material will constantly be exposed to the fluorine and will be continuously eroded. For this reason material selection is extremely important. Materials that form a good fluoride coating will be protected from further attack.

Fluorine reacts vigorously at ambient temperatures with most metals. The reaction intensity depends upon the surface area of the metal. Powdered metals or fine wires may react violently. Most inorganic materials react with fluorine; water forms hydrofluoric acid, and salts convert to fluorides. Contact with organic materials generally results in ignition or violent explosion.

Fire potential

The oxidizing potential of fluorine requires review of its fire potential. Let's look at the basic fire triangle. All three legs of the triangle must be present to produce a fire—a fuel, an oxidizer, and an ignition source. Fluorine satisfies the oxidizer requirement. If asked to name some fuels, materials like wood, coal, oil and gas would be mentioned. But would anyone list materials like aluminum, steel, stainless steel? What is the primary reason we can light a piece of wood with a match but not a steel rod? The ignition temperature of the wood is much lower than that of the steel rod, and the heat from the match is sufficient for ignition. In the case of oxidizers, as the concentration of the oxidizer increases, the ignition temperature of potential fuels lowers. So materials that cannot be ignited in normal air may burn readily in oxi-

dizer atmospheres. With this in mind, we can see that in an oxidizer system we have two legs of the fire triangle present. The oxidizer is one leg and the materials of construction in the system are the fuels, or second leg. All that is required for an ignition is an energy source.

Now let's consider ignition sources. Typical sources of ignition would be fire, open flames, sparks, cigarettes, etc. But that is in the world of normal air. The autoignition temperature is the lowest temperature required to ignite a material in the absence of a flame or spark. Could gas velocity, friction, adiabatic heat or contamination provide the ignition source? Yes.

In the case of gas velocity, it is not the flow of gas that can cause ignition, but a particle that has been propelled by the gas and impacts the system with sufficient force to ignite. The heat generated may be sufficient to start a fire, depending on the material impacted. Friction from a component that is malfunctioning or operating poorly can generate heat. Friction between two materials generates fine particles, which may ignite from the heat generated.

Adiabatic heat of compression is a unique form of the simple heat of compression. Simple heat of com-

pression causes the temperature of a system to rise. An example would be a tire pump. The barrel or compression chamber builds heat as the pump compresses air. This process occurs relatively slowly and the system takes on the heat. Adiabatic heat of compression is caused by the rapid pressurization of a system where the gas absorbs the energy and the gas temperature rises. This heating occurs at the point of compression or the point where the flow of gas is stopped, such as at a valve or regulator seat. Depending on the material in use where the hot gas impinges, the heat may be sufficient to ignite the material. Precautions should be taken to limit the direct exposure of more flammable materials.

All of these energy sources can be enhanced by the presence of a contaminant. Contaminants are typically easier to ignite than the components of the system. If they react with the oxidizer, they may generate sufficient heat to propagate a reaction to the system.

Ignitions typically take place at points in the systems that are more vulnerable to the effects of the above ignition mechanisms. Particle impingement is more likely in an area that changes the direction of flow, such as an elbow. Adiabatic heat is generated in dead ends and created by valves or regulators. If the valve or regulator has a seat made of a nonmetallic material, it may be more prone to ignition because nonmetals typically have lower ignition temperatures than metals. If the ignition of the nonmetal generates enough heat, the ignition may propagate to the metal. This is called the kindling chain, where ignition is promoted from materials of low ignition temperature to materials of higher ignition temperatures.

Contamination not only in the form of particles can lead to ignition. Other

contaminants, such as hydrocarbons can be easily ignited in oxidizer systems. They can potentially burn with sufficient heat to propagate the ignition to system components. This is another example of the kindling chain.

In an effort to relate the fire potential of fluorine to oxygen, Air Products conducted ignition tests. The test apparatus consisted of a specially designed chamber into which a 1/4" carbon steel rod was placed. The rod was specially designed to promote ignition, and a magnesium igniter was placed onto the rod. This test apparatus allowed ignition comparisons to be made with various concentrations of fluorine and oxygen up to and including full cylinder pressures. These ignition tests showed fluorine to be about 2.5 times more reactive than oxygen. The tests also resulted in 10% to 20% range of fluorine in nitrogen at 13,790 kPa (2000 psig) as being unable to support ignition of the steel rod. This information should not be misinterpreted to say 10% to 20% range of fluorine in nitrogen does not promote ignition of other materials, especially since the fire chemistry may vary greatly, depending on the fuel.

Figure 1: Typical Manifold

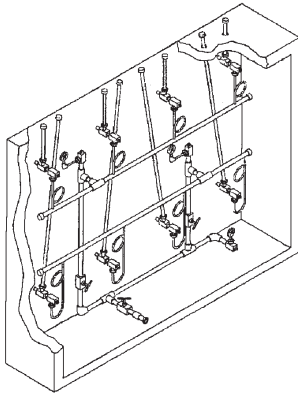
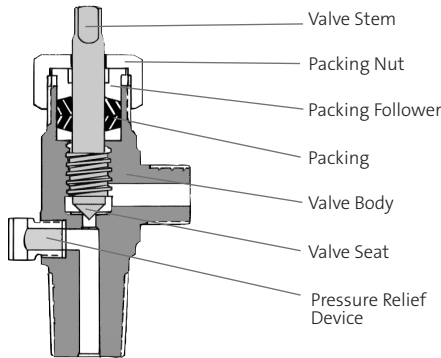

Figure 2: Packed Valve without Handwheel (wrench operated)



Warning

Improper use of cylinder valves may result in serious injury!

Containers

Mixtures of 10% to 20% range of fluorine in nitrogen are shipped and stored in highpressure cylinders, tube trailers or ISO modules, depending on the quantity required by the consumer. These containers are manufactured according to applicable codes and specifications for the temperatures and pressures involved.

Cylinders

A cylinder is a hollow tube with a closed concave base that permits the cylinder to stand upright. The opposite end is tapered to a small opening that is threaded to accommodate the installation of a valve. A threaded neck ring is attached to the tapered end to allow a protective cylinder valve cap to be installed. Cylinders are sometimes manifolded together in a pack or bank to provide larger volumes while minimizing cylinder changes.

Tube trailers and ISO modules

If large amounts of product are required, 10% to 20% range of fluorine in nitrogen mixtures can be supplied in tube trailers or ISO modules. The most common configurations for these units are in four or eight tube bundles of 12 M (40 ft) by 56 cm (22 in) diameter tubes. These units carry as much as 820 kg (1800 lb) of product. See Figure 1 for an example of a typical manifold that would be found on a tube trailer or ISO module of 10% to 20% range of fluorine in nitrogen mixture.

Valves and connections

Valves

There are two different types of valves used on tube trailers, cylinders, and ground storage (hydрил) tubes containing 10% to 20% range of fluorine and nitrogen mixtures.

The packed valve without handwheel

The wrench-operated packed valve (See Figure 2) is used in both the aluminum silica bronze alloy the 303 stainless steel version.

Products: Corrosives and Reactive Gases

Operating Principle: The wrench-operated valve is a packed valve with a one-piece stem. The seat-to-stem seal is a metal-to-metal seal. The manufacturer's minimum recommended closing torque is 35 ft-lbs (47.5 N-m). This is much more than can be applied with hand force; therefore, the valve requires a wrench to provide sufficient closing force. The stem seal is accomplished by compressing a large ring of Teflon material between the valve body and packing nut, which forces the Teflon material to grip the stem.

Identifying features

1. The valve does not have a hand wheel. The top of the stem is machined square to accommodate a wrench.
2. The top of the valve has a large, internal- threaded nut screwed onto the body, where the valve's stem exits. This is the packing nut.

Recommended Opening Procedure:

The wrench-operated valve has a very large flow capacity. It is not necessary to open this valve to the full open position to provide full flow to the process. Opening this valve fully poses two serious problems. The first problem is safety-related. In many applications, cylinders with these valves

are used in tight quarters (e.g., gas cabinets) or behind barricades. These space constraints often prohibit the stem from being fully rotated when the valve is operating. This valve requires approximately three full turns from full open to full close. In the case of an emergency, it can take 15 to 30 seconds to close the valve, depending on space and operator stress. However, if the valve is opened to the recommended 1/4 to 1/2-turn, the valve can be quickly closed with minimal operator exposure. The second benefit of only opening the valve the recommended 1/4 to 1/2-turn is the protection of the upper section of threads.

The threads are in the wetted gas stream and, due to the corrosive nature of many of the products where these valves are used, the threads can become jammed with corrosion by-products. If the valve is opened to the recommended 1/4 to 1/2-turn and the threads become jammed, the upper threads usually remain clear. This allows the operator to further open the valve and to free the threads. The proper operation of this valve requires the use of the proper tools. The Air Products recommended opening procedure for this valve is as follows:

1. Connect the cylinder to the system.
2. Use an appropriate tool to open slowly the valve.
3. Continue opening the valve until it is 1/4 to 1/2-turn open.

Where possible, leave the tool on the valve so that a quick closing of the valve can be done in the event of an emergency.

Recommended Closing Procedure:

Use an appropriate tool to close the valve. The minimum closing torque for this valve is 35 ft-lbs (475 N-m), but it is not uncommon for some valves to require as much as 60 to 80 ft-lbs (80 to 110 N-m)

Caution: Some valves may become worn or collect debris in the seat causing difficulty obtaining a complete seal. If the valve does not completely seal, call the Emergency Response System for instructions for the next steps.

Valve Advantages: The valve is extremely rugged and its one piece stem provides positive operation. This strength and the metal sealing allow this valve to be used in the most severe services. The simple design makes this valve very reliable.

Valve Disadvantages: The nature of the products for which this valve is used is the main cause of problems with this valve. Corrosion products often deposit at the valve seat, preventing a seal, or they collect in the threads, making operation difficult or impossible. As the seat wears, increasing closing torque is required to seal the valve. The packing is also susceptible to both inboard and outboard leakage. This is caused by the same property that makes Teflon material such ideal packing: its ability to flow. When the Teflon material is squeezed, it responds by “cold flowing.” This means the Teflon material pushes into every void in an effort to relieve the pressure. When this happens, a packing leak often develops. The packing should be checked frequently for leaks. Depressurizing the valve outlet and retorquing the packing nut can usually stop packing leaks. These weak points make this valve a poor choice for cylinders used in critical applications where cleanliness and

ultrahigh leak integrity are crucial.

Comments: A simple preventive maintenance program and good operating procedures can address and limit the disadvantages of this valve. Preventive maintenance in the form of weekly cycling to keep the threads clear and frequent checking of the packing for leaks is very beneficial. Good procedures for cylinder change-outs and proper operation are key in minimizing problems with this valve. The right tool for valve operation also makes the operator’s job easier and safer.

Figure 3: Packed Valve (handwheel operated)

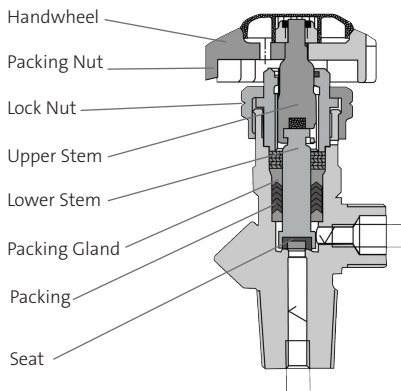

Warning

Improper use of cylinder valves may result in serious injury!

The Handwheel-Operated Packed Valve (Fig. 3)

Products: Corrosives and Reactive Gases

Operating Principle: The handwheel-operated packed valve can use metal-to-metal seats like the wrench-operated valve or elastomeric seats like the pressure seal valve. Unlike the wrench-operated valve, the sealing mechanism in this valve is designed to seal with only hand force. The packing is typically filled Teflon material. The packing is usually smaller and better contained than the packing in the wrench-operated valve. This helps to eliminate the packing leak problem associated with the wrench-operated valve. The packed valves used by Air Products employ a two- or three-piece stem in which the lower stem or spindle connects to the upper stem via a slip joint. In these valves the stem tip seals against the seat without rotating. This reduces some of the wear and particle generation, as compared to the wrench-operated design. This sealing motion and a considerable reduction in seat size allow this valve to be operated using hand torque. The packing nut of this valve is secured by a lock nut with left-handed threads, which prevents accidental loosening of the packing nut.

Identifying Features

1. The valve is equipped with a hand wheel. The handwheel does not hold a spring and does not wiggle like the handwheel of a pressure seal valve.
2. The stem rises when the hand wheel is turned to the open position.
3. Beneath the handwheel are two nuts attached to the valve body. The upper set of wrench flats belong to the packing nut, which is threaded into the valve body. The lower set of wrench flats belong to the locking nut. Note that these flats have notches machined into them. This indicates the locking nut has left-handed threads.

Recommended Opening Procedure:

The slip joint interface of the upper and lower stems creates a free play of about 1/2-turn with this valve. In some instances when opening, especially with metal-to-metal seat valves, the handwheel will give an initial resistance and then suddenly turn about 1/2-turn with little resistance. At this point the valve is still closed. When the handwheel hits resistance again, this is the sealing force at the seat. The handwheel must be turned at least another 1/2-turn, or a full turn from initial start, for the valve to be opened. This handwheel rotates three full turns from closed to fully open. The flow capacity of this valve is much smaller than that of the wrench-operated valve; therefore, it may be desirable to open this valve fully. **DO NOT** backseat this valve. Open the valve fully and then rotate the handwheel clockwise about 1/2 turn. This position will provide maximum flow and allow the quickest closing in the event of an emergency. It will also eliminate the chance of an open valve being mistaken for a closed valve.

Figure 4: Typical Gasketed Cylinder Valve Outlet Connection

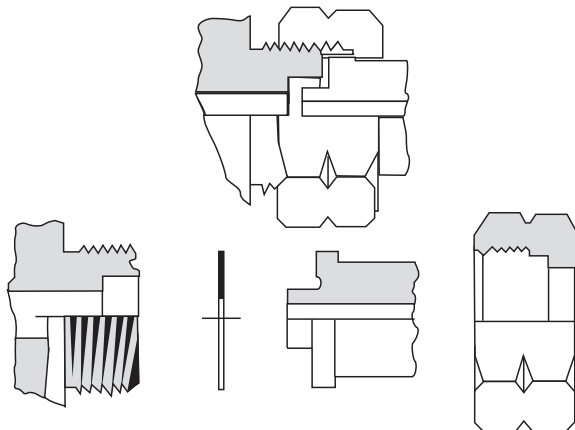

Recommended Closing Procedure:

Close the cylinder valve tightly using a gloved hand. Air Products recommends always wearing gloves when operating cylinder valves. NEVER use wrenches or other tools to operate the valve.

Valve Advantages: The valve can be used in many of the same services as the wrench-operated valve. No threads or lubricants are in the wetted gas stem. The valve effectively seals at higher pressures with less closing torque than the wrench-operated design. The packing design provides greater seal integrity than other packed valves. The valve is handoperated, thereby eliminating the need for special wrenches. The non-rotating lower stem eliminates much of the particle generation and wear associated with the wrench-operated packed valves.

Valve Disadvantages: Although this valve has better particle generation characteristics and leak integrity than other packed valves, diaphragm valves are superior to these valves in these attributes. The stem design makes this a very rapid opening valve, and it should not be used in services where gas velocity and adiabatic heat of compression are a concern (such as in oxidizer service). The dead band in the stem prohibits the use of any presently available separate pneumatic openers.

Comments: This valve is typically used to replace the wrench-operated valve in non-ultrahigh integrity applications. In some applications where the consumer uses a yoke to connect to the cylinder, the valve is not equipped with a handwheel.

Connections

Several different valve outlet connections are used on containers of 10% to 20% range of fluorine in nitrogen mixtures. Cylinders filled in the United States are equipped with valves having a CGA-330 valve outlet connection while cylinders filled in the European Union have a Number 8 valve outlet connection as per the German DIN 477 guidelines. ISO modules and tube trailers are only filled in the United States, and the tube valves use the CGA-679 valve outlet connection. Although these connections differ in dimensions, the CGA connections have left-handed threads, and the DIN connections have right-handed threads, they are all gasketed connections.

Gasketed connections have four parts: the valve outlet, the nipple, the nut and the gasket. The valve outlet sealing surface and the sealing surface of the nipple are both flat to accom-

modate the squeezing of a gasket between the two surfaces. The nut is used to pull the nipple to the valve outlet and applies the sealing force to the gasket. The selection of gasket material is critical to the successful seal of the connections. The gasket must be pliable enough to conform to the sealing surface while not being so pliable as to cold flow when under pressure. The gasket material must also be compatible with the product as well as any by-products that may be formed when the product comes in contact with the ambient atmosphere. The different connections utilize different materials for their gaskets. The Number 8 DIN 477 uses copper, the CGA 679 lead-coated copper, and the CGA 330 15% calcium fluoride filled PTFE. Metal gaskets usually require between 30 to 45 ft/lb (41 to 61 N-m) of torque, while the PTFE gaskets require between 15 to 25 ft/lb (20 to 34 N-m) of torque to achieve an adequate seal. **Table 4** shows a typical gasketed valve connection and its parts.

Table 4: Transportation Information

Hazard Class	2.3 (poison gas)
Health Effects	10% F2/N2 LC50 = 1850 ppm 1 hr. rat (calculated) 20% F2/N2 LC50 = 925 ppm 1 hr. rat (calculated)
Shipping Label	Poison Gas, Oxidizer, Corrosive
Shipping Name	Compressed Gas, Toxic, Oxidizing, Corrosive, N.O.S., (Fluorine, Nitrogen), 2.3 (5.1, 8), UN3306, Poison – Inhalation Hazard, Zone C (for 10% mixture) , and Zone B (for 20% mixture)
Identification Number	UN 3306
Special Shipping Information	Cylinders should be transported in a secure, upright position. Never transport in passenger compartment of a vehicle. Always ensure the cylinder valve is closed, outlet seal is installed gas tight and protective cap is in place before shipping. Tube trailers and ISO modules should have all tube valves closed and the manifold should be vented with the manifold valve closed and outlet seal installed gas tight.

Pressure relief devices

Cylinders filled in the European Union are not equipped with pressure relief devices. Cylinders, tube trailers and ISO modules filled in the United States are currently equipped with CG-4 combination frangible disk with fusible alloy backing pressure relief devices. These devices require that the pressure rating of the disk and the temperature requirement of the fusible alloy both be satisfied before the device will relieve.

Storage and handling

Always store and handle fluorine mixtures and other compressed gases in accordance with ISO Standard 11625, "Gas cylinders — Safe handling." International or local regulations may require additional safeguards for storage or use. Personnel must know and understand the properties, proper uses, and safety precautions for the specific product before using the product or associated equipment.

Storage

Cylinders should be secured in an upright position and stored in a well-ventilated area protected from the weather. The storage area should be secure with limited access. The toxicity of these materials requires area monitoring where these materials are stored and used. Storage area temperatures should not exceed 50°C (122°F) and should be free from combustible materials and free from ignition sources. Storage should be away from heavily traveled areas and emergency exits. Avoid areas where salt or other corrosive materials are present. Valve protection caps and valve outlet seals must remain on unconnected cylinders. When returning a cylinder to storage, the valve outlet seal must be installed leak-tight. Separate full and empty cylinders. Avoid excess inventory and storage time. Visually inspect stored cylinders on a routine basis, at least weekly, for any indication of leakage or other problems. Use a first-in, first-out inventory system and keep up-to-date inventory records. The use of "FULL," "IN USE," and "EMPTY" tags is highly recommended. Some locales require special planning when storage of these materials exceeds a specific amount. Storage areas must be posted with the proper signage, such as, "No Smoking or Open Flames."

Handling and Use

Use only in well-ventilated areas. Use a suitable handcart designed for cylinder movement. Do not drag, roll or slide cylinders. Never attempt to lift a cylinder by its cap. Secure cylinders at all times during storage, transport and use. Never apply flame or local heat to any part of a cylinder. Do not allow any part of the cylinder to exceed 50°C (122°F). High temperature may cause damage to the cylinder. If user experiences any difficulty operating the cylinder valve, discontinue use and contact the supplier. Use an adjustable strap wrench to remove overly tight cylinder caps. Never insert anything into the cap holes to assist in cap removal.

Ensure that the cylinder valve is properly closed, valve outlet seal has been reinstalled leak-tight, and valve protection cap is installed before returning to storage, moving or shipping the cylinder.

When using tube trailers or ISO modules, open only one tube at a time to minimize the amount of product available in case of a downstream equipment failure.

Use a pressure-reducing regulator or separate control valve to discharge gas from the container. Most metals are corroded by fluorine in the presence of moisture. Systems should be kept free of moisture. Thoroughly dry the system and purge with nitrogen before introducing the fluorine mixture. Always open valves slowly. Never pressurize the entire system at once, but introduce the gas in steps by opening and closing valves in succession. This will initially limit the amount of fluorine in the system should a leak or other problems occur. Do not use rapidly opening valves (i.e., ball valves). The use of rapidly opening valves may cause adiabatic heat of compression and possible ignition. Use a check valve to prevent reverse flow into the container.

Disposal

Return any unused product in the modules or cylinders to the supplier. Residual or process gas within the system should be neutralized by an approved scrubbing system. Typically these scrubbers will use a caustic solution (potassium hydroxide) or small particles of limestone (CaCO_3). Care must be taken to control the flow of gas to the scrubber in order to prevent overheating. Never use activated carbon or charcoal as a scrubber medium. Fluorine will absorb on these materials until an explosive reaction occurs.

System design and maintenance

Visually inspect the ISO module and associated piping on a daily basis. Check for signs of corrosion or leaks. If a leak or any other problem is observed, shut down the system and depressurize all associated piping. Next, purge the piping with nitrogen before attempting any repairs. Never work on a pressurized system. Make repairs as soon as possible since the corrosive nature of fluorine will continue to degrade the piping system over time. Due to this degradation, fluorine leaks tend to increase with time.

Operate cylinder or module valves routinely (monthly) to ensure they function properly. For wrench operated valves, this is accomplished by further opening and then reclosing the valve 1/2-turn. This action will not affect the flow of gas to the blending system. Reverse this procedure for cylinders that may contain packed valves with handwheels. First close the valve completely, and reopen the valve 1/2-turn.

Piping systems that use fluorine mixtures will over time become contaminated with a powdery residue over time. This material is composed of metal fluorides and should be handled with caution since the material may contain small amounts of hydrofluoric acid. It should also be assumed that any liquids or moisture found in these fluorine systems would contain hydrofluoric acid. This material is very corrosive to skin and many other materials of construction.

All piping systems should be designed and maintained to prevent accidental contamination, mixing, or backflow of other gases into the module or cylinder delivery systems. These supply systems should be purged with nitrogen before fluorine is introduced for moisture removal. Never leave piping systems pressurized with fluorine mixtures for long periods of time when not in use. Idle piping systems should be kept closed and under slight nitrogen pressure (69 kPa, 10 psig) when not in use.

Compatible Material

Consideration must always be given to reactive by-products of fluorine (hydrogen fluoride) and their properties when selecting materials of construction to use with these mixtures. In addition, thought should also be given to ambient conditions, the presence of other chemicals, and the effect that they may have on the storage, handling, and use of fluorine mixtures. Carbon steel, stainless steel, or copper, are suitable materials of construction for use with these mixtures. Monel and nickel are preferred materials for high-temperature applications. Lead is the preferred gasket material. Avoid brass because of its reaction (dezincification) with hydrogen fluoride that may be formed in systems containing fluorine mixtures. Most metals will form a passive fluoride film that protects the metal from further corrosion. PCTFE and Teflon are the preferred elastomers for use with these mixtures. The use of elastomers should be kept to a minimum, especially in higher pressure or high concentration applications.

Any equipment that uses these mixtures should first be thoroughly cleaned, rinsed with solvent (degreased), and dried with nitrogen, not compressed air. The equipment should then be treated with increasing concentrations of fluorine as a final cleaning process. These mixtures will react with and eliminate any impurities without ignition of equipment or piping and will impart a protective fluoride layer. This passivation step can also be accomplished by introducing the 10% to 20% range

of mixture into the system at reduced pressures. The pressure of the mixture may then be increased slowly over a period of time (5 hours) until the final maximum pressure is reached.

Before transporting these modules or cylinders, a final check should be made on the modules' manifold pressure gauges. The tube valves should hold so that no pressure is observed on the modules' manifold. When shipping single cylinders, always ensure that the cylinder valve is closed tightly, the outlet seal is installed gas tight, and a protective cap is in place.

If there are questions concerning the compatibility of these fluorine mixtures with other materials, contact Air Products.

Personal protective equipment

General Use: Use of a respirator* with a dust filter is recommended when exposure to metal fluorides is possible. Wear leather gloves, safety glasses, and safety shoes when handling cylinders. Wear loose-fitting leather gloves, face shield, safety glasses, and long-sleeved shirt or jacket when connecting, disconnecting, or opening cylinders, or whenever the possibility for exposure exists.

Systems that have been purged clean of the fluorine/nitrogen mixture still may contain hydrofluoric acid. Wear chemical-resistant gloves, outer garment, and face shield when disassembling system components.

Emergency: Use self-contained breathing apparatus (SCBA) or positive-pressure airline with full-face mask in areas where the fluorine concentration is above 0.1 ppm. Wearing loose-fitting leather gloves and a leather welders jacket is also recommended.

First Aid

It is very important to preplan first aid and treatment for fluorine and hydrofluoric acid exposures because of their unique properties. Supply local medical facilities with information on treatment, and ensure that materials and procedures for treatment are in place.

Air Products' Safetygram-29, "Treatment Protocol for Hydrofluoric Acid Burns," provides detailed first aid and medical treatment information. This document can be used to preplan response to a burn with suggested medical treatments and necessary medical supplies.

***Note:** There is no approved respirator available for fluorine.

Fire fighting

Cylinders exposed to high heat or flame may rupture violently. In regions where cylinder valves on 10% to 20% range of fluorine in nitrogen mixtures are equipped with pressure relief devices, the cylinder contents may be released, minimizing the potential for a cylinder failure under high temperature or fire conditions. Where no pressure relief devices are used, the potential for catastrophic failure of a cylinder in a fire is much greater. If a container of 20% fluorine in nitrogen is involved in a fire, cool the container with water spray if this can be done safely. If possible, without risk, move containers away from the fire area. Although the mixture is nonflammable, it will vigorously support combustion. Most extinguishing media will react with this mixture and will not extinguish the fire. If the mix is feeding the fire, try to shut off the source if possible.

Hydrogen fluoride and other toxic fluorides may be produced as products of combustion. Besides the danger these products pose to personnel they may also contaminate the runoff from fire fighting.

Emergency Response System

T 800-523-9374 (Continental U.S. and Puerto Rico)

Korea: 080-222-8880

Taiwan: 0800-014000

China :(0) 532 8388 9090

Malaysia: 1 800 88 7844

Singapore: +65 6853 6800

Brazil: 0800-0190-900

Argentina: 0800-444-8089

Chile: 600-600-3030

Colombia: 600-600-3030

Ecuador: 600-600-3030

Peru: 600-600-3030

T +1-610-481-7711 (other locations) – for regional ER telephone numbers please refer to the local SDS 24 hours a day, 7 days a week for assistance involving Air Products and Chemicals, Inc. products.

Product Safety Information

For MSDS airproducts.com/MSDS

For safetygrams airproducts.com/safetygrams

For product safety information airproducts.com/productsafety

Technical Information Center

T 800-752-1597 (U.S.)

T +1-610-481-8565 (other locations)

Monday–Friday, 8:00 a.m.–5:00 p.m. EST

F 610-481-8690

gastech@airproducts.com

Information Sources

Compressed Gas Association (CGA) www.cganet.com European Industrial Gas Association (EIGA)

www.eiga.org Asia Industrial Gas Association (AIGA) www.asiaiga.org American Chemistry

Council (ACC) www.americanchemistry.com

For more information, please contact us at:

Corporate Headquarters

Air Products and Chemicals, Inc.

1940 Air Products Blvd.

Allentown, PA 18106-5500



GENERATING A CLEANER FUTURE